

Building Strong LEGO Structures

Q. What's a **FLU**?

A. A **Fundamental LEGO Unit**, of course.

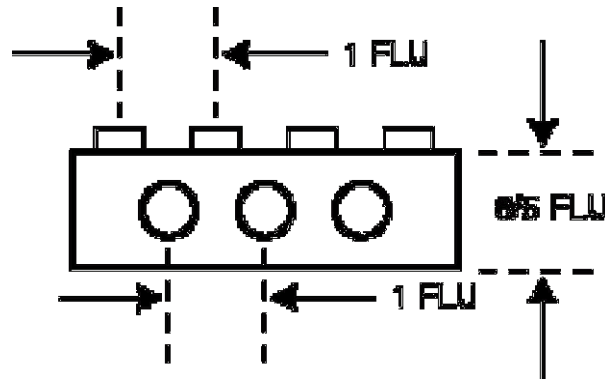

One key to strong LEGO structures is **vertical bracing**, using **beams** and **pegs**.

Try stacking a bunch of beams together and vertically bracing them. Chances are the holes don't line up:

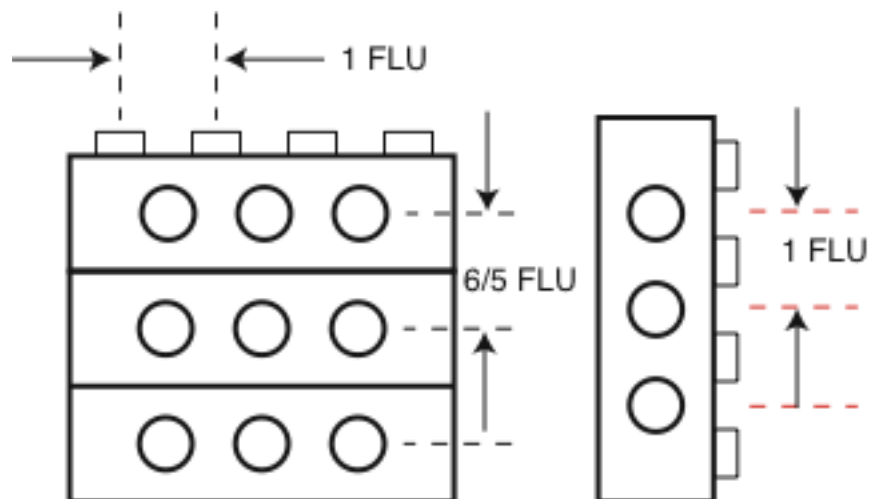

Fortunately LEGO plates come to the rescue:

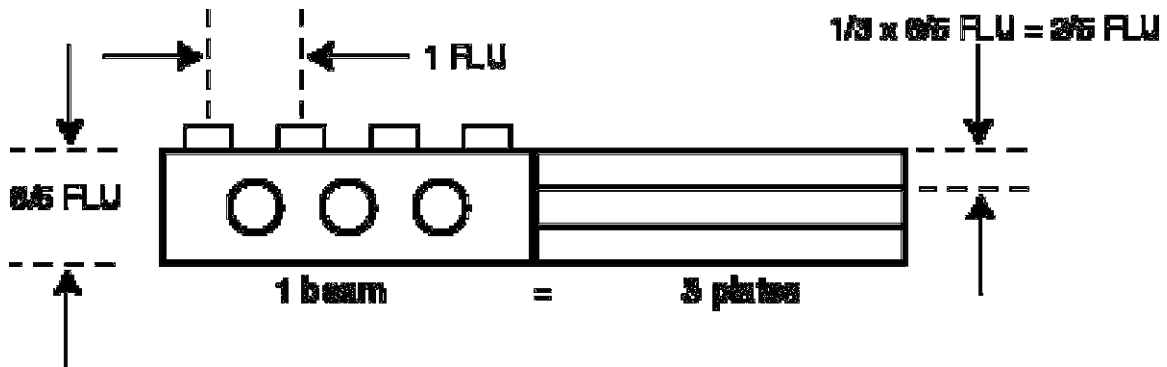

Three plates have the same vertical dimension as one beam ($\frac{6}{5}$ FLU), so each plate has a thickness of

$$\frac{1}{3} \times \frac{6}{5} = \frac{2}{5} \text{ FLU.}$$

Plates can be used to adjust the vertical spacing so that it is equal to an integral number of FLUs. For example, the beams in the stack below have holes separated by exactly 2 FLU in the vertical direction:

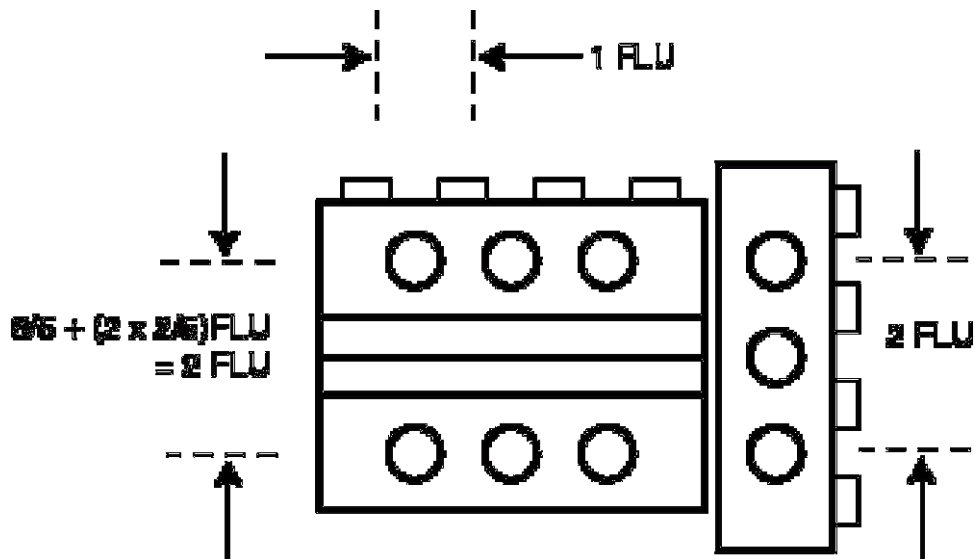

This enables one to build very strong structures, like the one shown below.

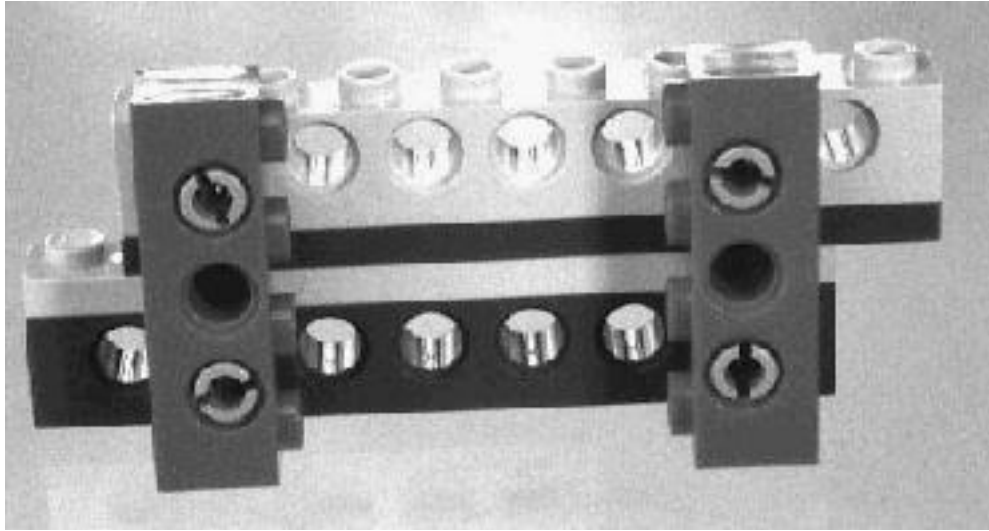

Q. That's a neat trick! What other arrangements are possible?

A. Since the plates are $2/5$ FLU high, we can build vertical separations of thickness $p \times 2/5$ FLU, where p is the number of plates used. For vertical bracing to work, we require that

$$p \times 2/5 = \text{an integer}$$

For example the figure below shows an arrangement where the pegged holes (indicated by the dotted lines) are separated by 4 FLU.

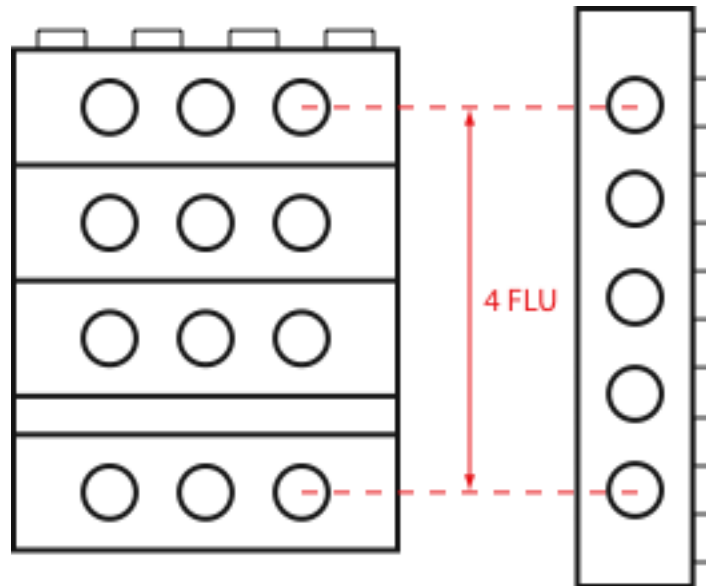

In the above stack, each beam is equivalent to three plates, and there are effectively three beams and one plate in the stack, so the effective number of plates in the stack is:

$$p = (3 \times 3) + 1 = 10$$

so that the separation between the top and bottom holes is:

$$10 \text{ plates} \times 2/5 \text{ FLU/plate} = 4 \text{ FLU}$$

Can you think of other possible vertical bracing arrangements?